

# radicon

with you at every turn

Series X Flexible Couplings

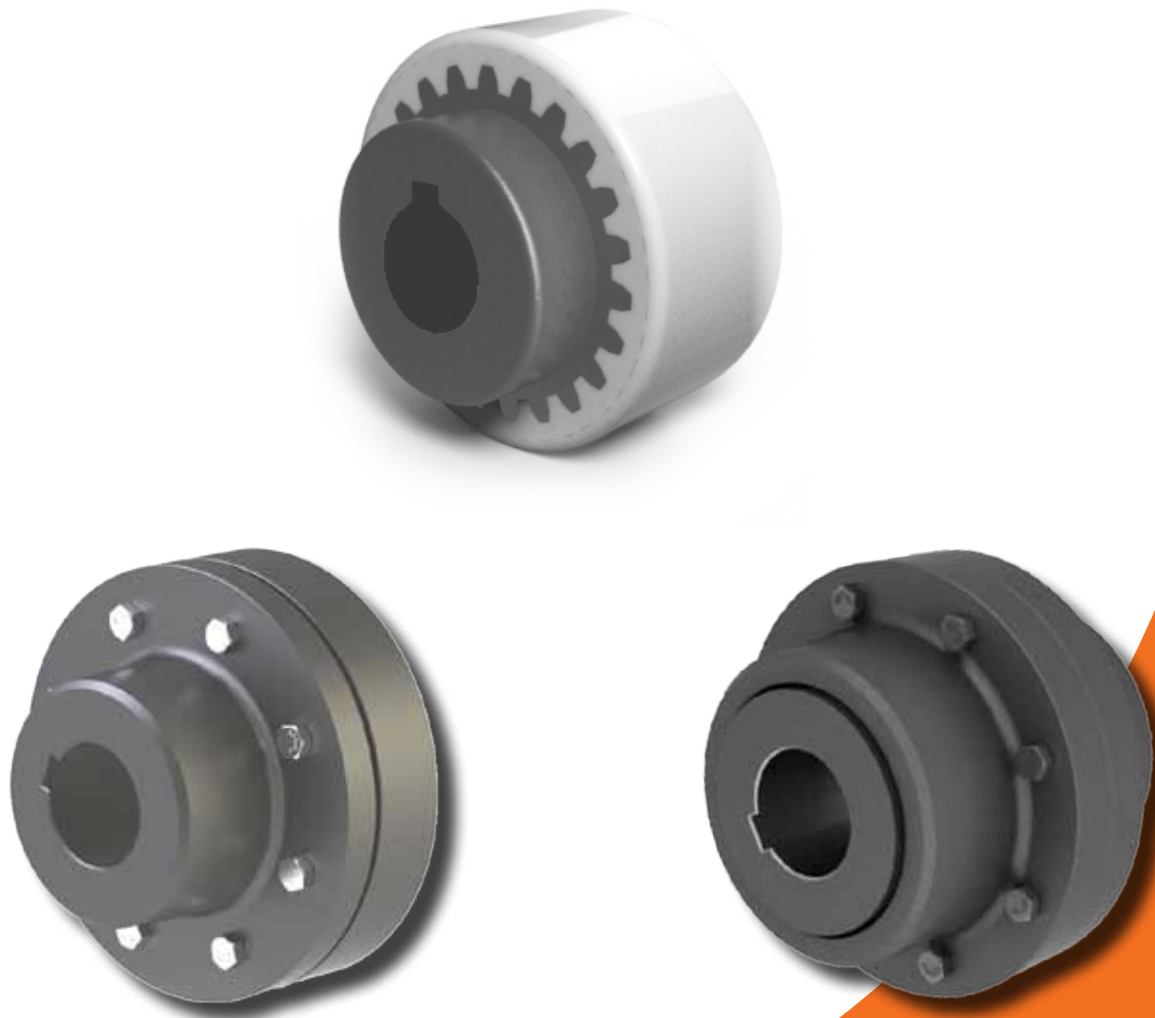

Flexible Couplings  
CX-3.00GB0613

# PRODUCTS IN THE RANGE

Serving an entire spectrum of mechanical drive applications from food, energy, mining and metal; to automotive, aerospace and marine propulsion, we are here to make a positive difference to the supply of drive solutions.

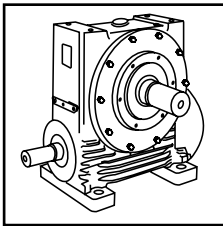

**Series A**  
Worm Gear units  
and geared motors  
in single & double  
reduction types

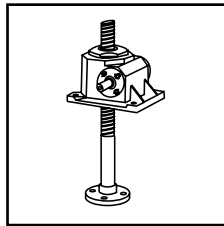

**Series BD**  
Screwjack worm  
gear unit

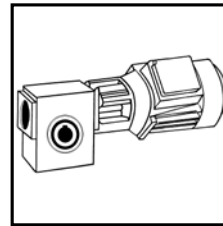

**Series BS**  
Worm gear unit

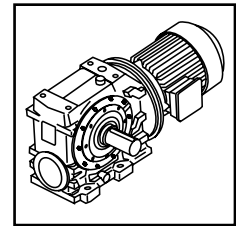

**Series C**  
Right angle drive  
helical worm geared  
motors & reducers

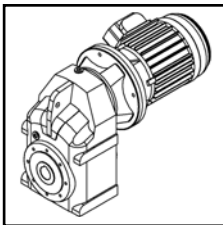

**Series F**  
Parallel shaft helical  
geared motors &  
reducers

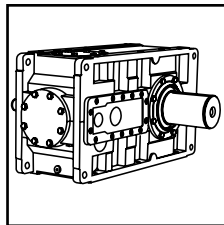

**Series G**  
Helical parallel shaft  
& bevel helical right  
angle drive gear  
units

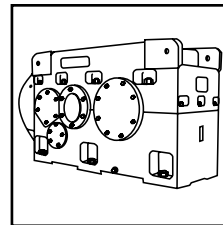

**Series H**  
Large helical parallel  
shaft & bevel helical  
right angle drive units

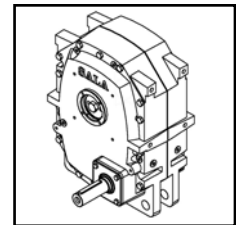

**Series J**  
Shaft mounted  
helical speed  
reducers

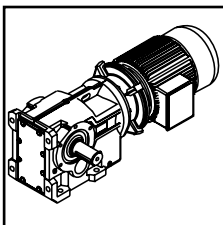

**Series K**  
Right angle helical  
bevel helical geared  
motors & reducers

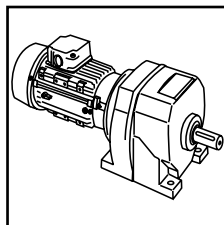

**Series M**  
In-line helical geared  
motors & reducers

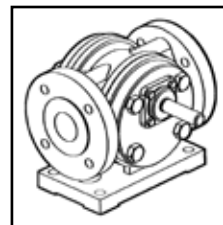

**Roloid Gear Pump**  
Lubrication and fluid  
transportation pump

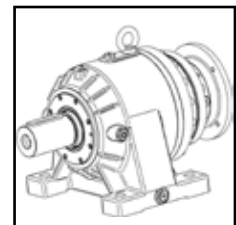

**Series P  
Planetary**  
Foot and flange  
mounted planetary  
units

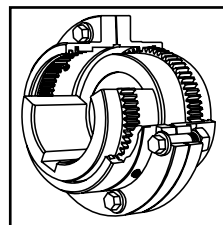

**Series X  
Elign Gear**  
Torsionally rigid,  
high torque coupling

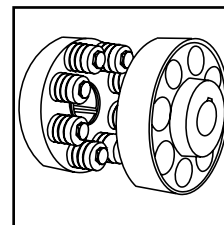

**Series X  
Elflex**  
Pin and bush  
elastomer coupling

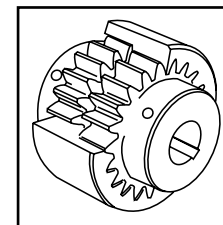

**Series X  
Nylicon**  
Gear coupling with  
nylon sleeve

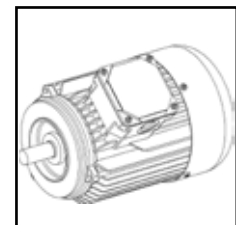

**Motors**  
Full range of IEC  
motors



We offer a wide range of repair services and many years experience of repairing demanding and highly critical transmissions in numerous industries.

We can create custom engineered transmission solutions of any size and configuration.

# COUPLINGS

## CONTENTS

Introduction _____	2
Selection _____	3
Load Classification By Application _____	4
Coupling Designations _____	5
<b>Elign Gear Type Couplings</b> _____	7 - 10
Type ED Double Engagement _____	11 - 12
Type ED Single Engagement _____	13 - 14
Type ET Spacer Tube _____	15 - 16
Type EV Vertical Type _____	17
Type ES Continuous Sleeve _____	18
Type ERR Fully Rigid _____	19
<b>Elflex Flexible Pin &amp; Bush Couplings</b> _____	21 - 22
Type EFC Elflex Coupling _____	23
Type FC Elflex Coupling _____	24
Type EFC Elflex Coupling With Taperlock Bush _____	25
Type FBC Elflex Coupling With Brake Drum _____	26
<b>Nylicon Gear Couplings</b> _____	27 - 28
Nylicon Gear Couplings with Nylicon Sleeve _____	29

### Couplings

Our range of couplings have been proven to be some of the most reliable, durable and effective couplings in the marketplace. These qualities have been achieved by our attention to detail in design, manufacturing capabilities and application expertise. This ensures our coupling range is capable of providing solutions for a wide and varied range of applications and installations.

### Elign Gear Couplings

The Elign range of gear couplings not only connect two rotating shafts, but also accommodate the inevitable misalignment that can occur in installations. The Elign gear coupling is ideally suited to accommodate Radial, Angular and combined Radial and Angular misalignment, whilst also permitting axial movement of the shaft.

The Elign coupling range comes in 6 types – single engagement, double engagement, spacer type, vertical type, fully rigid and continuous sleeve.

**Output Torque: Up to 1.1 Million Nm**

**Shaft Diameters: Up to 540 mm**

### Elfex Pin & Bush Couplings

The Elfex range of pin and bush couplings are ideally suited for applications where a limited amount of misalignment of the shaft is unavoidable. Elfex flexible couplings are cushioned drive type couplings, which transmit the torque through rubber bushes which have an excellent capacity to absorb shocks. The Elfex range is available in 26 sizes.

The Elfex pin and bush range is available up to the following specifications -

**Output Torque: Up to 43,000 Nm**

**Shaft Diameters: Up to 460 mm**

### Nylicon Couplings

Nylicon couplings compensate for all types of shaft misalignment and are a cost effective solution for low power applications. They are easy to assemble and require zero maintenance offering a reliable low cost solution even in the most arduous and harshest of conditions.

The Nylicon coupling range is available in 3 sizes and up to the following specifications -

**Output Torque: Up to 463 Nm**

**Shaft Diameters: Up to 55 mm**

# COUPLINGS

## SELECTION

### Mechanical Ratings and Service Factor

The mechanical ratings are a measure of the couplings capacity in terms of life and strength, they assume 10 hours/day operation under uniform loading conditions and allow for a 100% momentary overload at starting or braking

The mechanical Service Factor (fm) is selected dependant on the type of prime mover, the classification of the driven load, and duration of operation

- i) Obtain the driven load classification type from the table Load Classification by Application
- ii) Determine the mechanical service factor from the table below:

Prime Mover	Operating Duty Hours/ Days	Load Classification Drive machine		
		U Uniform	M Moderate	H Heavy
Electric Motor Hydraulic Motor	< 3	0.80	1.00	1.50
	3 to 10	1.00	1.25	1.75
	>10	1.25	1.50	2.00
Piston Engine >3 cylinders	< 3	1.00	1.25	1.75
	3 to 10	1.25	1.50	2.00
	>10	1.50	1.75	2.25
Piston Engine 1-3 Cylinders	< 3	1.25	1.50	2.00
	3 to 10	1.50	1.75	2.25
	>10	1.75	2.00	2.50

### Key to symbols:

<b>P</b>	= Power transmitted (kW)
<b>N</b>	= Operating speed (rpm)
<b>P/N</b>	= kW/rpm
<b>Fm</b>	= Mechanical Service Factor
<b>Tk</b>	= Torque Rating (daNm)
<b>Tk (max)</b>	= Maximum allowable torque (daNm)
<b>J</b>	= Moment of Inertia kg m <sup>2</sup>
<b>N (max)</b>	= Maximum Speed (rpm)
<b>M</b>	= Space required for alignment or replacing seal.

Compute the Required Rating, **P/N** (kW/rpm), or the effective torque **Tk** (daNm)

$$P/N \text{ (effective)} = \frac{P \text{ (kW)} \times f_m}{N \text{ (rpm)}}$$

$$Tk \text{ (daNm)} = \frac{955 \times P \text{ (kW)} \times f_m}{N \text{ (rpm)}}$$

### Select the Coupling

Use the coupling dimension pages to select the coupling type that matches or exceeds the required rating and has a physical size to accommodate the driving and driven shafts

Check the maximum speeds of the application against the maximum speed ratings N (max)

Check the dimensions of the selected coupling compared with the space limitations of the application, ensure there is adequate clearance of shaft extensions, to allow for separation of the coupling parts to align or maintain.

Check that the bore and keyway capacity is adequate for the required duty.

# COUPLINGS

## LOAD CLASSIFICATION BY APPLICATION

**Load Classifications** - U =Uniform Load M =Moderate Shock Load H =Heavy Shock Load † =Consult our Engineers

<b>Agitators</b>		<b>Elevators</b>		<b>Machine Tools</b>		<b>Pumps</b>	
Pure liquids	U	Bucket - Uniform load	U	Bending roll	M	Centrifugal proportioning	U
Liquids and solids	M	Bucket - Heavy load	M	Punch press	H	Proportioning	M
Liquids variable density	M	Bucket - Continuous	U	Notching press	H	Reciprocating	
		Centrifugal discharge	U	Plate planer	H	Single acting 3+ cylinders	M
<b>Blowers</b>		Escalators	U	Other machine tools		Double acting 2+ cylinders	M
Centrifugal	U	Freight	M	Main drive	M	Single acting 1 & 2 cylinders	†
Lobe	M	Gravity discharge	U	Aux drive	U	Double acting 1 cylinder	†
Vane	U	Passenger lifts	†			Rotary- gear type	U
				<b>Metal mills</b>		Rotary- lobe type/ vane	U
<b>Brewing &amp; distilling</b>		<b>Fans</b>		Carriage/main drive	M		
Bottling machinery	M	Centrifugal	U	Draw bench	M	<b>Sand muller</b>	M
Brew Kettles	M	Cooling towers		Dryer	M		
Cookers	M	Induced draft	†	Flattening machinery	M	<b>Sewage treatment</b>	
Mash tubs	M	Forced draft	†	Pinch drive	M	Bar screen	U
Scale hopper	M	Fan - Large diameter induced draft	M	Reversing slitters	M	Chemical feeder	U
		Fan - Light, small diameter	M	Scrubber rolls	M	Collector	U
				Table conveyors		Dewatering screw	M
<b>Can filling machinery</b>	M	<b>Feeders</b>		Group drives	H	Mixers	M
		Apron	M	Individual drives	H	Scum breaker	M
<b>Crane knife</b>	M	Belt	M	Table conveyors- reversing	H	Thickness	M
		Disc	U	Wire draw	M	Vacuum filters	M
<b>Car dumper</b>	M	Reciprocating	H	Wire roll	M		
		Screw	M			<b>Screens</b>	
<b>Car puller</b>	M			<b>Mills</b>		Air washing	U
		<b>Food industry</b>		Cement kiln	H	Rotary, stone or gravel	M
<b>Clarifier</b>	U	Cereal cooker	U	Dryer, Cooler	H	Traveling water intake	U
		Dough mixer	M	Kiln (other)	H		
<b>Classifier</b>	M	Meat grinder	M	Rod plain	H	<b>Slab pushers</b>	M
		Meat slicer	M	Rod wedge bar	H		
<b>Clay wokring machinery</b>		<b>Generators - not welding</b>	U	Rotary/ Ball	H	<b>Slewing</b>	H
Brick press	H			Tumbling barrel	H		
Briquette machine	H	<b>Hammer mills</b>	H			<b>Steering gear</b>	†
Clay working machinery	M			<b>Mixers</b>			U
Plug mill	M	<b>Hoists</b>		Concrete	M	<b>Stokers</b>	
		Heavy duty	H	Cons density	U		
<b>Compressors</b>		Medium duty	M	Variable density	M	<b>Sugar industry</b>	
Centrifugal	U	Skip hoist	M			Can knife	M
Lobe	M			<b>Oil industry</b>		Crusher	M
Reciprocating		<b>Laundry</b>		Chiller's	M	Mills	M
Multi cylinder	M	Tumbler	M	Oil well pump	M		
Single cylinder	H	Washer	M	Filter press	M	<b>Textile industry</b>	
				Rotary kiln	M	Batchers	M
<b>Conveyors- Light duty uniform load</b>		<b>Line shafts</b>				Calenders	M
Apron	U	Heavy duty	M	<b>Paper industry</b>		Cards	M
Assembly	U	Light duty	U	Agitator (mixer)	M	Dry cans	M
Belt	U			Barker (hydraulic)	M	Dryers	M
Bucket	U	<b>Lumber industry</b>	M	Barker (mechanical)	H	Dyeing machinery	M
Chain	U	Barkers	M	Barking drum	H	Knitting machinery	M
Flight	U	Burner conveyor	H	Beater & Pulper	M	Looms	M
Oven	U	Chain/ Drag saw	H	Bleacher	U	Mangles	M
Screw	U	Chain transfer	H	Calendnders	M	Nappers	M
		Chain way transfer	H	Calenders- super	H	Pads	M
<b>Conveyors - Heavy duty uniform load</b>		De- barking drum	H	Converting machine	M	Range drive	M
Apron	M	Edger feed	M	Conveyors	U	Slashers	M
Assembly	M	Gang feed	M	Couch	M	Soapers	M
Belt	M	Green chain	M	Cutters - plates	H	Spinners	M
Bucket	M	Live roll	H	Cylinders	M	Tenter frame	M
Chain	M	Log deck	H	Dryers	M	Washers	M
Flight	M	Log haul	H	Felt stretcher	M	Winders	M
Live roll	†	Log turning	H	Felt whipper	H		
Oven	M	Log conveyer	H	Jordans	M	<b>Windlass</b>	†
Reciprocating	M	Of bearing roll	M	Log haul	H		
Screw	M	Planer feed chaines	M	Machine real	M		
Shaker	M	Planer hoist	M	Presses	M		
		Re-saw conveyer	M	Stock chest	M		
<b>Cranes</b>	†	Roll cases	H	Suction roll	M		
		Slab conveyer	H	Washers & thickeners	M		
<b>Crusher</b>		Sorting table - triple hoist	M	Winders	M		
Ore	H	Triple hoist - Drive /conveyor	M				
Stone	H	Transfer conveyer	M	<b>Printing presses</b>	†		
Sugar	H	Transfer roll	M				
		Tray drive	M	<b>Pullers</b>			
<b>Dredger</b>	M	Trimmer feed	M	Barge haul	H		
Cable reals	M	Waster conveyer	M				
Conveyors	M	Small waste conveyer (belt)	U				
Cutter head drive	H	Small waste conveyer (chain)	U				
Pumps	M						
Screen drive	H						
Stackers	M						
Winches	M						

# COUPLINGS

## DESIGNATIONS

### Order Code

Type	Coupling Size	Driving hub		Driven hub	
		Bore Type	Bore Size	Bore Type	Bore Size
Example- ED	1600	M	090	M	075

### Coupling Types

**ELIGN** - Gear type couplings

- ED** ELIGN Double engagement with flange
- ER** ELIGN Single engagement with flange
- ET** ELIGN Double engagement with spacer tube
- EV** ELIGN Double engagement for vertical operation
- ERR** ELIGN Fully rigid coupling
- ES** ELIGN Double engagement with continuous sleeve

**ELFLEX** - Pin and Bush type flexible couplings

- EFC** EFC - ELFLEX Standard coupling
- FC** FC - ELFLEX Standard coupling - larger size
- FBC** FBC - ELFLEX Coupling with integral brake drum

**NYLICON** - Nylon sleeve gear couplings

- X600** X600 - Nylicon coupling

### Bore Types

- ED** Metric bore parallel keyway (DIN6885/1)
- T** Metric bore taper keyway (DIN6886)
- A** American parallel keyway (USAS B17.1:1967)
- C** Customer specified
- P** Pilot bored
- B** Taper lock bush (Elflex only)

### Bore Sizes

- 090** E.g 90mm diameter (Metric Bore)
- 014** 0.875" diameter (Inch Bore) - See code below for American bore types
- For pilot or customer specified

### Standard American Bore Code and Bore Tolerances

Code	Bore Size	Code	Bore Size	Code	Bore Size
012	0.7498"/0.7493"	204	2.2501"/2.2494"	408	4.5002"/4.5003"
013	0.8123"/0.8118"	206	2.3751"/2.3744"	410	4.6252"/4.6243"
014	0.8748"/0.8743"	208	2.5001"/2.4994"	412	4.7502"/4.7493"
015	0.9373"/0.9368"	210	2.6251"/2.6244"	414	4.8752"/4.8743"
100	0.9998"/0.9993"	212	2.7501"/2.7494"	500	5.0002"/4.9993"
101	1.0623"/1.0618"	214	2.8751"/2.8744"	502	5.1252"/5.1243"
102	1.1248"/1.1243"	300	3.0001"/2.9994"	504	5.2502"/5.2493"
103	1.1873"/1.1868"	302	3.1251"/3.1244"	506	5.3752"/5.3743"
104	1.2498"/1.2492"	304	3.2502"/3.2493"	508	5.5002"/5.5003"
105	1.3123"/1.3117"	306	3.3752"/3.3743"	510	5.6252"/5.6243"
106	1.3748"/1.3742"	308	3.5002"/3.5003"	512	5.7502"/5.7493"
107	1.4373"/1.4367"	310	3.6252"/3.6243"	514	5.8752"/5.8743"
108	1.4998"/1.4992"	312	3.7502"/3.7493"	600	6.0002"/5.9993"
110	1.6248"/1.6242"	314	3.8752"/3.8743"	612	6.1252"/6.1243"
112	1.7498"/1.7492"	400	4.0002"/3.9993"	604	6.2502"/6.2493"
114	1.8748"/1.8742"	402	4.1252"/4.1243"	606	6.3752"/6.3743"
200	2.0001"/1.9994"	404	4.2502"/4.2493"	608	6.5002"/6.5003"
202	2.1251"/2.1244"	406	4.3752"/4.3743"		

# COUPLINGS

---

NOTES

---



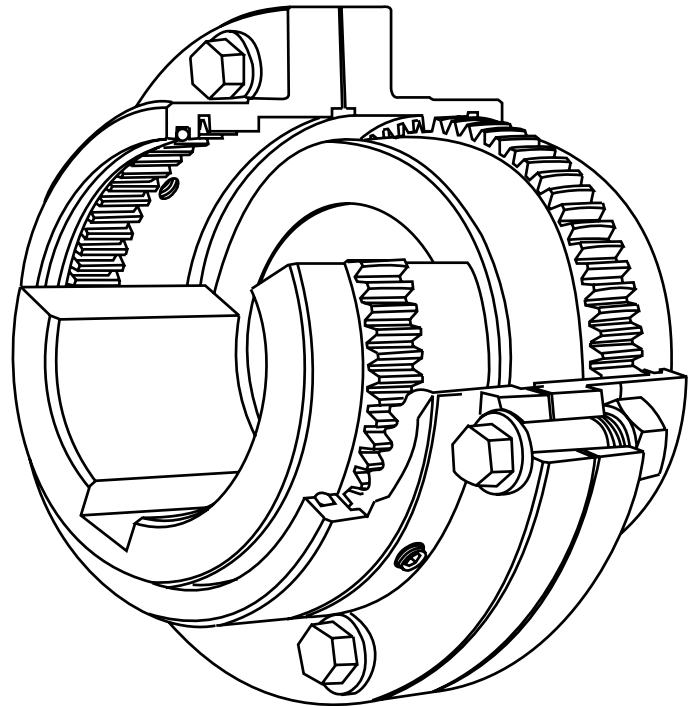

# **ELIGN**

## **GEAR TYPE COUPLINGS**

# COUPLINGS

## ELIGN GEAR COUPLINGS

### Features of ELIGN Gear Coupling

The ELIGN Gear Couplings consist of hubs with multi crowned teeth at the flank, tip and chamfer.

The ELIGN hub teeth are manufactured using the latest state of the art CNC machines, and are manufactured from quality forged carbon steel, and are subjected to a number of quality checks and tests.

The superior design of the multi- crowned tooth profile enables the ELIGN gear coupling to operate satisfactorily under all operating conditions with increased reliability and durability. The multi- crowned teeth are tolerant to misalignment whilst improving the load carrying capacity and minimising the level of backlash.

The ELIGN gear coupling is a simple, compact and light unit for transmitting maximum power

**Crowned Flanks:** The flanks of the teeth are crowned so that the tooth thickness is greatest at that centre of the tooth. This ensures a larger contact area per tooth for higher torque requirements and puts more teeth in contact for a given angle. The actual tooth loading takes place near the centre of the tooth face where the tooth thickness is greatest, crowned flanks also eliminate the end-of-tooth loading, providing optimal load distribution, and can accommodate all types of misalignment with minimum backlash.



**Crowned Tips:** The tips of the teeth are crowned. To allow accurate pivoting of the hub within the sleeve, this maintains a minimal diametric sleeve clearance and centres the sleeve physically to ensure a good dynamic balance under various loading and misalignment conditions.



**Crowned Chamfers:** The faces of the teeth adjacent to the tips and are chamfered to eliminate interference with the sleeve tooth fillets. This ensures maximum contact of the hub with the sleeve teeth and it also ensures the freedom of movement to accommodate misalignment



# COUPLINGS

## ELIGN GEAR COUPLINGS

### Gear Couplings

Gear Coupling are used to join two rotating shafts for efficient transmission of mechanical power.

Although the shafts can be accurately aligned at the time of installation, it is likely that during the operation the alignment may get disturbed due to settling of the foundation, thermal expansion, shaft deflection, wearing out of other parts, improper maintenance or many other reasons.

Due to unavoidable misalignment occurring during operation a Gear Coupling provides An ideal solution to compensate or minimise the effect of misalignment. Gear Couplings are therefore ideally suited for wide range of applications in the entire field of drive technology.

### Misalignment

The main function of any Gear coupling is not only to connect two rotating shafts but also to accommodate misalignment of the connecting shafts, The ELIGN Gear Coupling accommodates the following three types of misalignment.

ELIGN gear couplings will take care of misalignment at the published levels without any undue damage to the connected equipment, however at higher levels of misalignment the coupling life will be reduced. it is therefore extremely important to align the interconnecting shafts as precisely as possible during the initial installation as further misalignment can occur during operation.

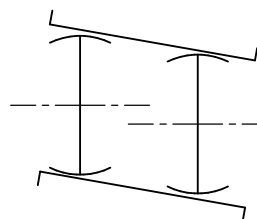
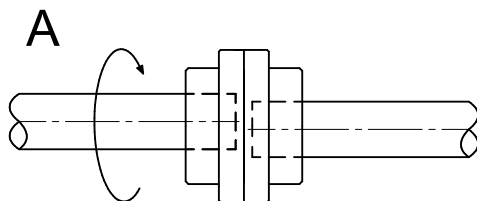

#### A. Radial

When axes of connected shafts are Parallel but not in the same straight line

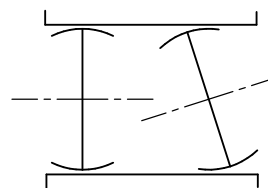
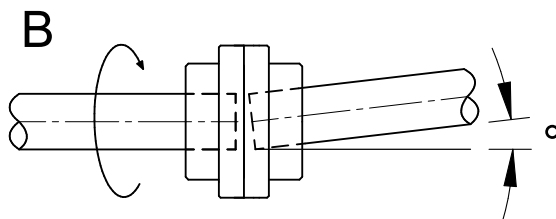

#### B. Angular

When axes of connected shafts intersect at the centre point of the coupling but not in the same straight line.

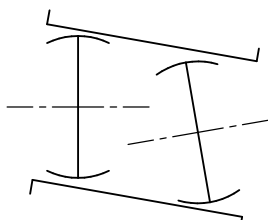
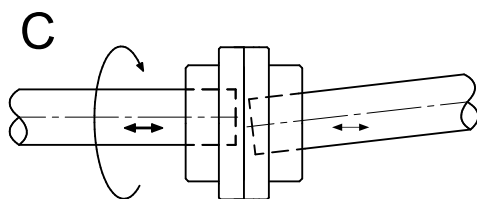

#### C. Combined Radial and Angular

When the axes of connected shafts do not intersect at the point of the coupling and are not parallel.

Besides the above three types of misalignment, the ELIGN Gear coupling range also permits some axial movement of the shaft.

# COUPLINGS

## ELIGN GEAR COUPLINGS

### Lifting Hole

The hubs of larger size couplings are supplied with lifting holes, as indicated on the dimension sheets.

### Lubrication

Each coupling half is provided with a grease nipple / plug from where grease can be filled directly. WARNING: Grease should be applied

### Protection

All components of ELIGN gear couplings have a rust preventative coating.

### Coupling Bores

Hubs are bored to suit the customers shaft size (see dimension tables for the minimum / maximum allowable bore) standard metric keyways conform to DIN-6885, PART-1 (unless otherwise specified)

Couplings can also be supplied bored to suit customers exact specifications or with the minimum / pilot bore conditions to permit machining by the customer. (the minimum / pilot bore is shown in brackets on the dimension pages)

### Key to symbols:

<b>P</b>	= Power transmitted (kW)
<b>N</b>	= Operating speed (rpm)
<b>P/N</b>	= kW/rpm
<b>Fm</b>	= Mechanical Service Factor
<b>Tk</b>	= Torque Rating (daNm)
<b>Tk (max)</b>	= Maximum allowable torque (daNm)
<b>J</b>	= Moment of Inertia kg m <sup>2</sup>
<b>N (max)</b>	= Maximum Speed (rpm)
<b>M</b>	= Space required for alignment or replacing seal.

### Types of ELIGN Gear Couplings

Type ED Double Engagement with Flange Sleeve

Type ER Single Engagement with Flange Sleeve

Type ET Spacer Type

Type EV Vertical Type

Type ES Continuous Sleeve

Type ERR Rigid Coupling

# COUPLINGS

## ELIGN GEAR COUPLINGS

### Type ED Double Engagement

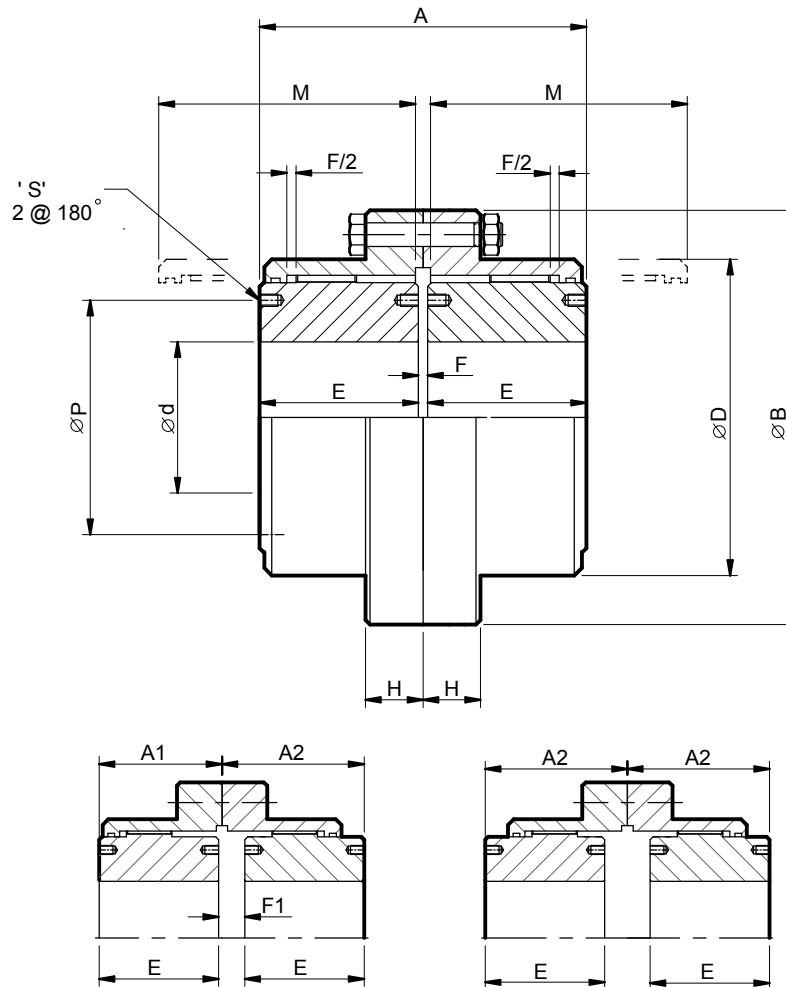





	Tk	Tk max	P / N	A	A1	A2	ØB	ØC	Ød	ØD	E	F	F1	H	M	ØP	S				J	N max
	daNm	daNm	kW/rpm	mm	mm	mm	mm	mm	mm	mm	mm	mm	mm	mm	mm	mm	mm	< °	+/- mm	kg	kgm <sup>2</sup>	rpm
ED130	130	260	0.14	89	44.5	53.5	111	67	15 - 45 (10)	80	43	3	12	14	74	-	-	2 X 0.75°	0.35	4	0.005	7000
ED280	280	560	0.29	103	51.5	57.5	141	87	20 - 60 (15)	103.5	50	3	9	19	84	-	-	2 X 0.75°	0.40	7	0.015	6200
ED500	500	1000	0.52	127	63.5	77.5	171	106	30 - 75 (25)	129.5	62	3	17	19	105	-	-	2 X 0.75°	0.50	14	0.039	5650
ED1000	1000	2000	1.05	157	78.5	90.5	210	130	35 - 95 (30)	156	76	5	17	22	123	-	-	2 X 0.75°	0.60	25	0.101	5100
ED1600	1600	3200	1.68	185	92.5	107	234	151	40 - 110 (35)	181	90	5	19	22	148	130	M8 x 12	2 X 0.75°	0.70	37	0.188	4700
ED2200	2200	4400	2.30	216	108	125	274	178	55 - 130 (50)	209	105	6	23	28.5	172	155	M8 x 12	2 X 0.75°	0.90	60	0.431	4350
ED3200	3200	6400	3.35	246	123	141	312	213	65 - 155 (60)	247	120	6	24	28.5	193	185	M10 x 15	2 X 0.75°	1.00	90	0.845	4000
ED4500	4500	9000	4.71	278	139	160	337	235	80 - 175 (75)	273	135	8	29	28.5	215	205	M12 x 18	2 X 0.75°	1.10	118	1.322	3800
ED6200	6200	12400	6.49	308	154	178	380	263	90 - 195 (85)	307	150	8	32	38	241	226	M16 x 24	2 X 0.75°	1.20	169	2.450	3600
ED8400	8400	16800	8.80	358	179	210	405	286	100 - 215 (95)	338	175	8	39	38	279	250	M16 x 24	2 X 0.75°	1.40	224	3.720	3450
ED11500	11500	23000	12.04	388	194	232	444	316	120 - 240 (115)	368	190	8	46	26	304	276	M16 x 24	2 X 0.75°	1.50	277	5.390	3300
ED17400	17400	34800	18.22	450	225	257	506	372	150 - 275 (145)	426	220	10	42	28.5	339	330	M20 x 30	2 X 0.75°	1.70	414	10.88	3050

# COUPLINGS

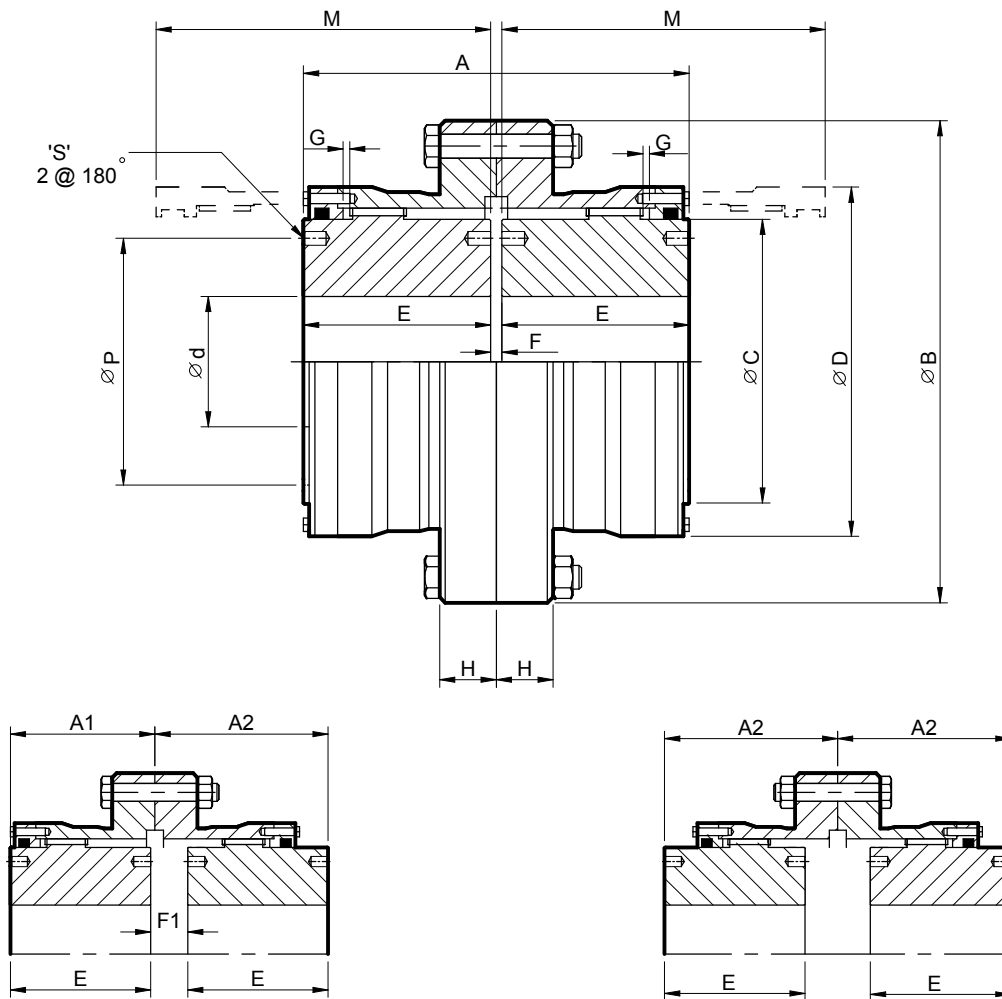
## ELIGN GEAR COUPLINGS

### Type ED Double Engagement











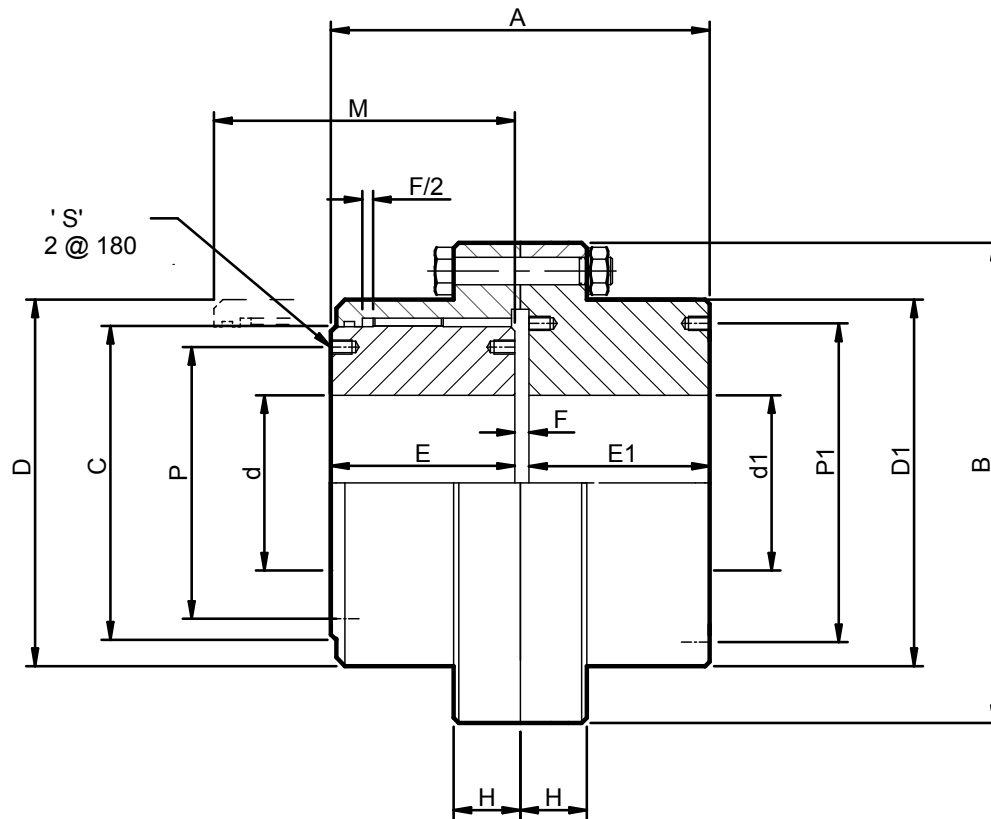





	Tk	Tk	P / N	A	A1	A2	ØB	ØC	Ød	ØD	E	F	F1	H	M	ØP	S				J	N
	daNm	daNm	kW/ rpm	mm	mm	mm	mm	mm	mm	mm	mm	mm	mm	mm	mm	mm		+/- mm	kg		max rpm	
<b>ED25200</b>	25200	50400	26.39	575	288	392	632	422	160 - 310 (155)	550	280	15	119	28	335	360	M20 x 30	2 X 0.75°	1.80	670	26.8	1830
<b>ED29000</b>	29000	58000	30.37	597	299	319	640	432	200 - 320 (195)	518	292	13	33	38	324	380	M20 x 30	2 X 0.75°	2.10	760	31.0	1800
<b>ED37000</b>	37000	74000	38.75	640	320	433	715	472	210 - 355 (205)	616	310	20	133	37	370	410	M24 x 40	2 X 0.75°	2.20	930	48.0	1460
<b>ED45000</b>	45000	90000	47.13	680	340	464	750	502	230 - 370 (225)	648	330	20	144	37	395	435	M24 x 40	2 X 0.75°	2.20	1110	65.8	1395
<b>ED56000</b>	56000	112000	58.64	713	357	405	804	594	280 - 450 (275)	682	350	13	61	38	379	544	M24 x 40	2 X 0.75°	2.70	1532	105	1300
<b>ED75000</b>	75000	150000	78.54	845	423	519	910	620	290 - 480 (285)	812	410	25	121	38	485	550	M36 x 55	2 X 0.75°	3.00	2180	198	1000
<b>ED90000</b>	90000	180000	94.25	885	443	520	980	670	320 - 515 (315)	860	430	25	102	46	510	585	M36 x 55	2 X 0.75°	3.00	2520	265	940
<b>ED110000</b>	110000	220000	115.20	925	463	535	1020	700	330 - 540 (325)	908	450	25	97	46	530	615	M36 x 55	2 X 0.75°	4.00	2910	333	900

# COUPLINGS

## ELIGN GEAR COUPLINGS

### Type ER Single Engagement





	Tk	Tk max	P / N	A	ØB	ØC	Ød	Ød1	ØD	ØD1	E	E1	F	H	M	ØP	ØP1	S			J	N max
	daNm	daNm	kW/rpm	mm	mm	mm	mm	mm	mm	mm	mm	mm	mm	mm	mm	mm	mm	mm	< °	kg	kgm <sup>2</sup>	rpm
ER130	130	260	0.14	88	111	67	15 - 45 (10)	15 - 55 (10)	80	80	43	40	5	14	74	-	-	-		4	0.005	7000
ER280	280	560	0.29	102	141	87	20 - 60 (15)	20 - 75 (15)	104	104	50	47	5	19	84	-	-	-		8	0.015	6200
ER500	500	1000	0.52	125	171	106	30 - 75 (25)	30 - 95 (25)	130	126	62	58	5	19	105	-	-	-		14	0.039	5650
ER1000	1000	2000	1.05	156	210	130	35 - 95 (30)	35 - 110 (30)	156	152	76	74	6	22	123	-	-	-		26	0.102	5100
ER1600	1600	3200	1.68	183	234	151	40 - 110 (35)	40 - 130 (35)	181	178	90	87	6	22	148	130	155	M8 x 12		38	0.196	4700
ER2200	2200	4400	2.30	213	274	178	55 - 130 (50)	55 - 155 (50)	209	208	105	101	6.5	28.5	172	155	180	M8 x 12		61	0.450	4350
ER3200	3200	6400	3.35	240	312	213	65 - 155 (60)	65 - 180 (60)	247	245	120	113	6.5	28.5	193	185	210	M10 x 15		91	0.871	4000
ER4500	4500	9000	4.71	272	337	235	80 - 175 (75)	80 - 200 (75)	273	270	135	129	8	28.5	215	205	235	M12 x 18		120	1.37	3800
ER6200	6200	12400	6.49	308	380	263	90 - 195 (85)	90 - 230 (85)	307	305	150	150	8	38	241	226	265	M16 x 24		175	2.59	3600
ER8400	8400	16800	8.80	358	405	286	100 - 215 (95)	100 - 250 (95)	338	330	175	175	8	38	279	250	290	M16 x 24		232	3.91	3450
ER11500	11500	23000	12.04	390	444	316	120 - 240 (115)	120 - 280 (115)	368	362	190	190	10	26	304	276	320	M16 x 24		287	5.66	3300
ER17400	17400	34800	18.22	453	506	372	150 - 275 (145)	150 - 330 (145)	426	416	220	220	13	28.5	339	330	370	M20 x 30		430	11.50	3050

# COUPLINGS

## ELIGN GEAR COUPLINGS

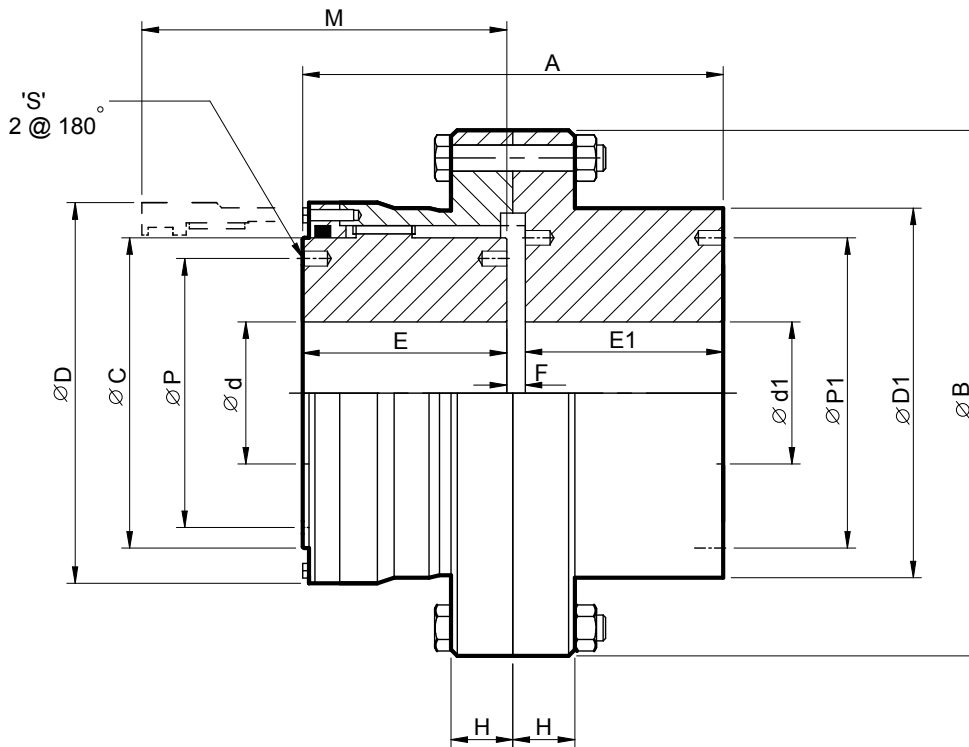
### Type ER Single Engagement



	Tk	Tk max	P / N	A	ØB	ØC	Ød	Ød1	ØD	ØD1	E	E1	F	H	M	ØP	ØP1	S			J	N max
	daNm	daNm	kW/rpm	mm	mm	mm	mm	mm	mm	mm	mm	mm	mm	mm	mm	mm	mm	mm	< °	kg	kgm <sup>2</sup>	rpm
<b>ER25200</b>	25200	50400	26.39	572	632	422	160 - 310 (155)	160 - 340 (155)	550	470	280	280	12	28	335	360	395	M20 x 30	0.75°	706	26.2	1830
<b>ER29000</b>	29000	58000	30.37	599	640	432	200 - 320 (195)	200 - 365 (195)	518	512	292	292	14.5	38	324	380	455	M20 x 30	0.75°	820	33.5	1880
<b>ER37000</b>	37000	74000	38.75	637	715	472	210 - 355 (205)	210 - 380 (205)	616	535	310	310	16.5	37	370	410	445	M24 x 40	0.75°	984	48.3	1460
<b>ER45000</b>	45000	90000	47.13	677	750	502	230 - 370 (225)	230 - 410 (225)	648	570	330	330	16.5	37	395	435	480	M24 x 40	0.75°	1170	64.0	1395





# COUPLINGS

## ELIGN GEAR COUPLINGS

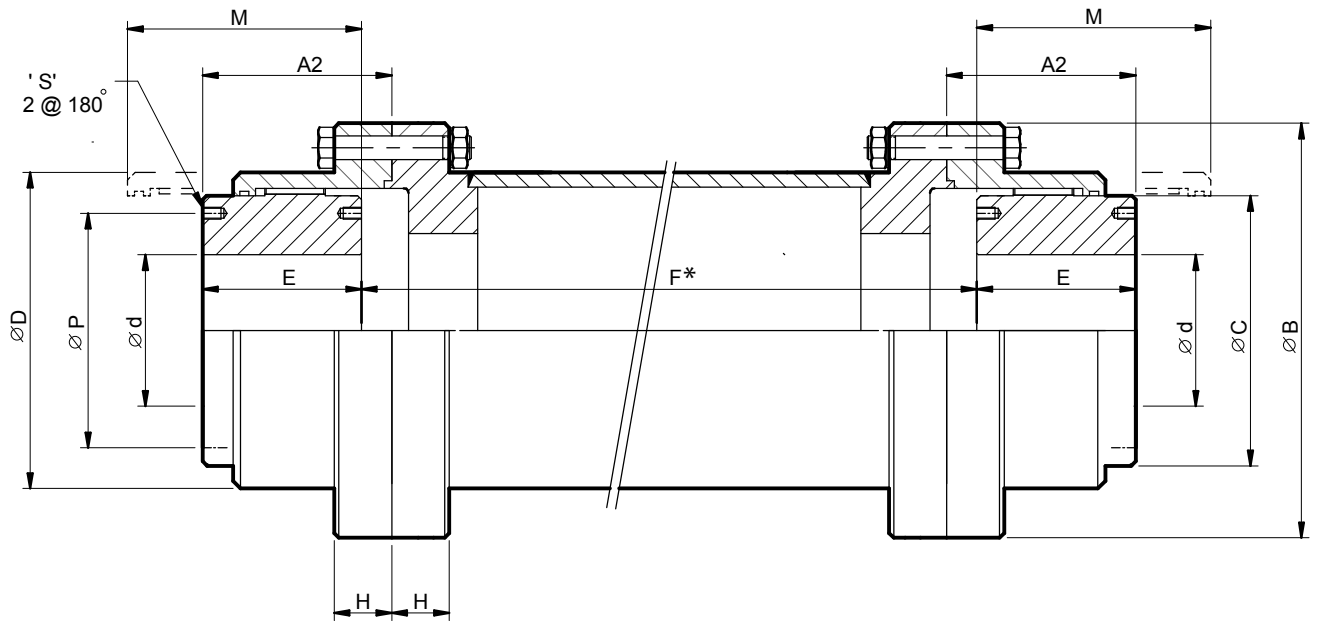
### Type ET Spacer Tube





	Tk	Tk max	P / N	A2	ØB	ØC	Ød	ØD	E	F	H	M	ØP	S		
	daNm	daNm	kW/rpm	mm	mm	mm	mm	mm	mm	mm	mm	mm	mm	mm	< °	+/- mm
ET130	130	260	0.14	53.5	111	67	15 - 45 (10)	80	43	*	14	74	-	-	2 X 0.75°	1.50
ET280	280	560	0.29	57.5	141	87	20 - 60 (15)	104	50	*	19	84	-	-	2 X 0.75°	1.50
ET500	500	1000	0.52	77.5	171	106	30 - 75 (25)	130	62	*	19	105	-	-	2 X 0.75°	1.50
ET1000	1000	2000	1.05	90.5	210	130	35 - 95 (30)	156	76	*	22	123	-	-	2 X 0.75°	2.50
ET1600	1600	3200	1.68	107	234	151	40 - 110 (35)	181	90	*	22	148	130	M8 x 12	2 X 0.75°	2.50
ET2200	2200	4400	2.30	125	274	178	55 - 130 (50)	209	105	*	29	172	155	M8 x 12	2 X 0.75°	3.00
ET3200	3200	6400	3.35	141	312	213	65 - 155 (60)	247	120	*	29	193	185	M10 x 15	2 X 0.75°	3.00
ET4500	4500	9000	4.71	160	337	235	80 - 175 (75)	273	135	*	29	215	205	M12 x 18	2 X 0.75°	4.00
ET6200	6200	12400	6.49	178	380	263	90 - 195 (85)	307	150	*	38	241	226	M16 x 24	2 X 0.75°	4.00
ET8400	8400	16800	8.80	210	405	286	100 - 215 (95)	338	175	*	38	279	250	M16 x 24	2 X 0.75°	4.00
ET11500	11500	23000	12.04	232	444	316	120 - 240 (115)	368	190	*	26	304	276	M16 x 24	2 X 0.75°	4.00
ET17400	17400	34800	18.22	257	506	372	150 - 275 (145)	426	220	*	29	339	330	M20 x 30	2 X 0.75°	5.50

# COUPLINGS

## ELIGN GEAR COUPLINGS

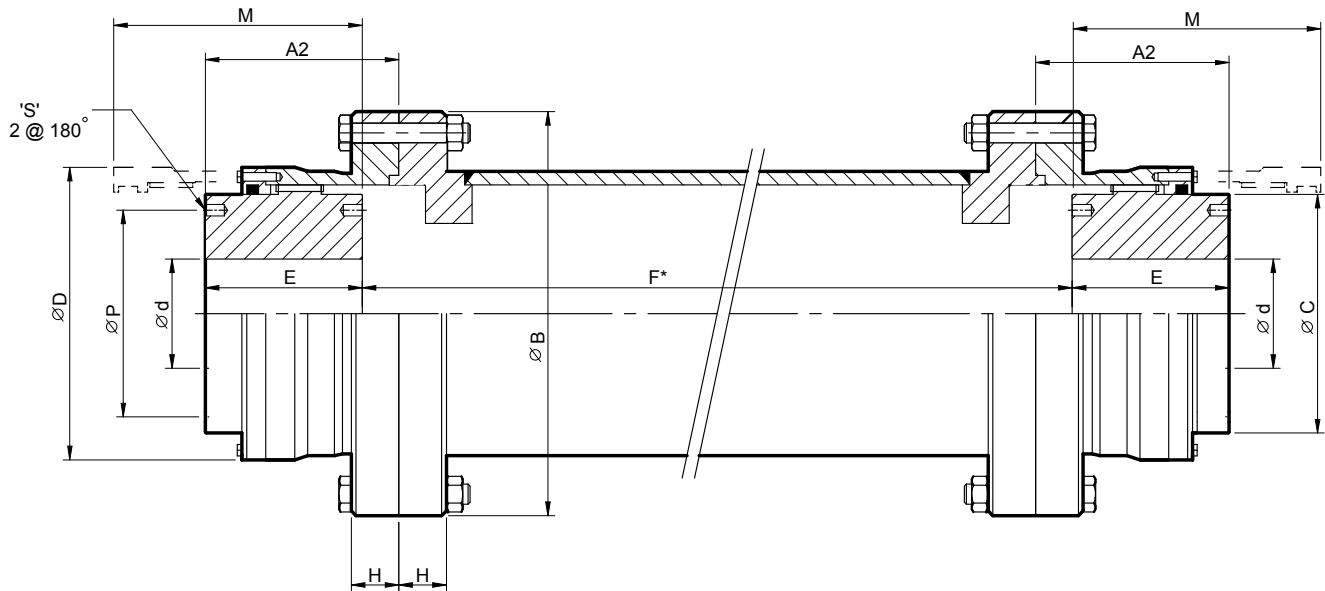
### Type ET Spacer Tube



	Tk	Tk max	P / N	A2	ØB	ØC	Ød	ØD	E	F	H	M	ØP	S		
	daNm	daNm	kW/rpm	mm	mm	mm	mm	mm	mm	mm	mm	mm	mm	mm	< °	mm
ET25200	25200	50400	26.39	392	632	422	160 - 310 (155)	550	280	*	28	335	360	M20 x 30	2 X 0.75°	10.00
ET29000	29000	58000	30.37	319	640	432	200 - 320 (195)	518	292	*	38	324	380	M20 x 30	2 X 0.75°	6.50
ET37000	37000	74000	38.75	433	715	472	210 - 355 (205)	616	310	*	37	370	410	M24 x 40	2 X 0.75°	12.00
ET45000	45000	90000	47.13	464	750	502	230 - 370 (225)	648	330	*	37	395	435	M24 x 40	2 X 0.75°	11.50
ET56000	56000	112000	58.64	405	804	594	280 - 450 (275)	682	350	*	38	379	544	M24 x 40	2 X 0.75°	6.50
ET75000	75000	150000	78.54	519	910	620	290 - 480 (285)	812	410	*	38	485	550	M36 x 55	2 X 0.75°	10.50
ET90000	90000	180000	94.25	520	980	670	320 - 515 (315)	860	430	*	46	510	585	M36 x 55	2 X 0.75°	15.50
ET110000	110000	220000	115.20	535	1020	700	330 - 540 (325)	908	450	*	46	530	615	M36 x 55	2 X 0.75°	4.00

# COUPLINGS

## ELIGN GEAR COUPLINGS

### Type EV Vertical Coupling

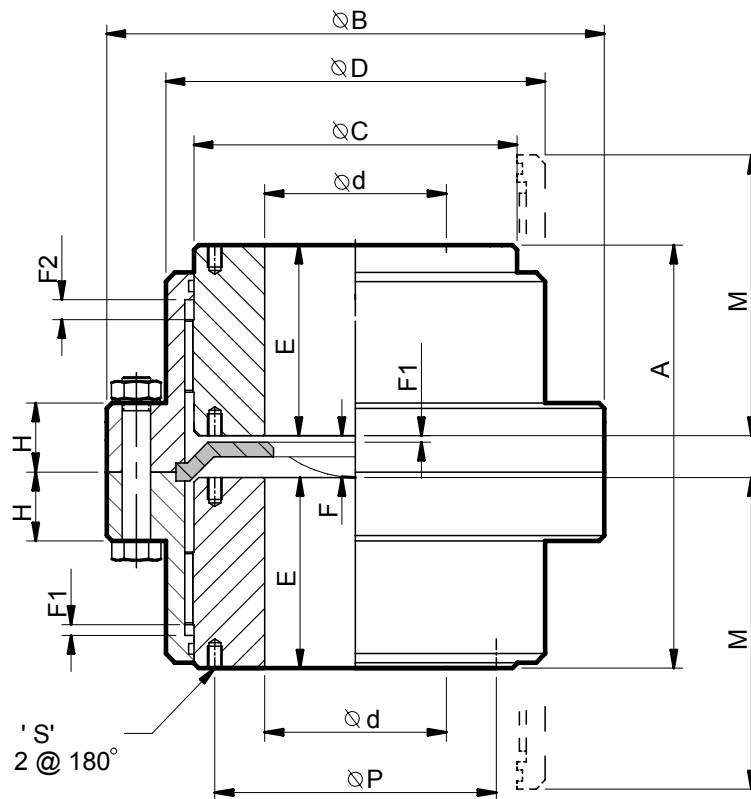





	Tk	Tk max	P / N	A	ØB	ØC	Ød	ØD	E	F	F1	F2	H	M	ØP	S				J	N max
	daNm	daNm	kW/rpm	mm	mm	mm	mm	mm	mm	mm	mm	mm	mm	mm	mm	mm	< °	+/- mm	kg	kgm <sup>2</sup>	rpm
EV130	130	260	0.14	94	111	67	15 - 45 (10)	80	43	8	1.5	5.5	14	74	-	-	2 X 0.75°	0.35	4.5	0.006	5000
EV280	280	560	0.29	105	141	87	20 - 60 (15)	104	50	5	1.5	5.5	19	84	-	-	2 X 0.75°	0.40	8.5	0.017	4400
EV500	500	1000	0.52	137	171	106	30 - 75 (25)	130	62	13	1.5	6	19	105	-	-	2 X 0.75°	0.50	15	0.043	4000
EV1000	1000	2000	1.05	163	210	130	35 - 95 (30)	156	76	11	2.5	8.5	22	123	-	-	2 X 0.75°	0.60	26	0.110	3600
EV1600	1600	3200	1.68	193	234	151	40 - 110 (35)	181	90	12.5	2.5	8.5	22	148	130	M8 x 12	2 X 0.75°	0.70	39	0.206	3350
EV2200	2200	4400	2.30	224	274	178	55 - 130 (50)	209	105	14	3	12	29	172	155	M8 x 12	2 X 0.75°	0.90	61	0.461	3100
EV3200	3200	6400	3.35	255	312	213	65 - 155 (60)	247	120	15	3	12	29	193	185	M10 x 15	2 X 0.75°	1.00	93	0.935	2800
EV4500	4500	9000	4.71	287	337	235	80 - 175 (75)	273	135	17	4	16	29	215	205	M12 x 18	2 X 0.75°	1.10	122	1.454	2700
EV6200	6200	12400	6.49	320	380	263	90 - 195 (85)	307	150	20	4	16	38	241	226	M16 x 24	2 X 0.75°	1.20	175	2.710	2500
EV8400	8400	16800	8.80	377	405	286	100 - 215 (95)	338	175	27	4	16	38	279	250	M16 x 24	2 X 0.5°	0.90	236	4.320	2450
EV11500	11500	23000	12.04	414	444	316	120 - 240 (115)	368	190	34	4	16	26	304	276	M16 x 24	2 X 0.5°	1.00	295	6.480	2300
EV17400	17400	34800	18.22	468	506	372	150 - 275 (145)	426	220	28	5	20	29	339	330	M20 x 30	2 X 0.5°	1.10	430	11.00	2150

# COUPLINGS

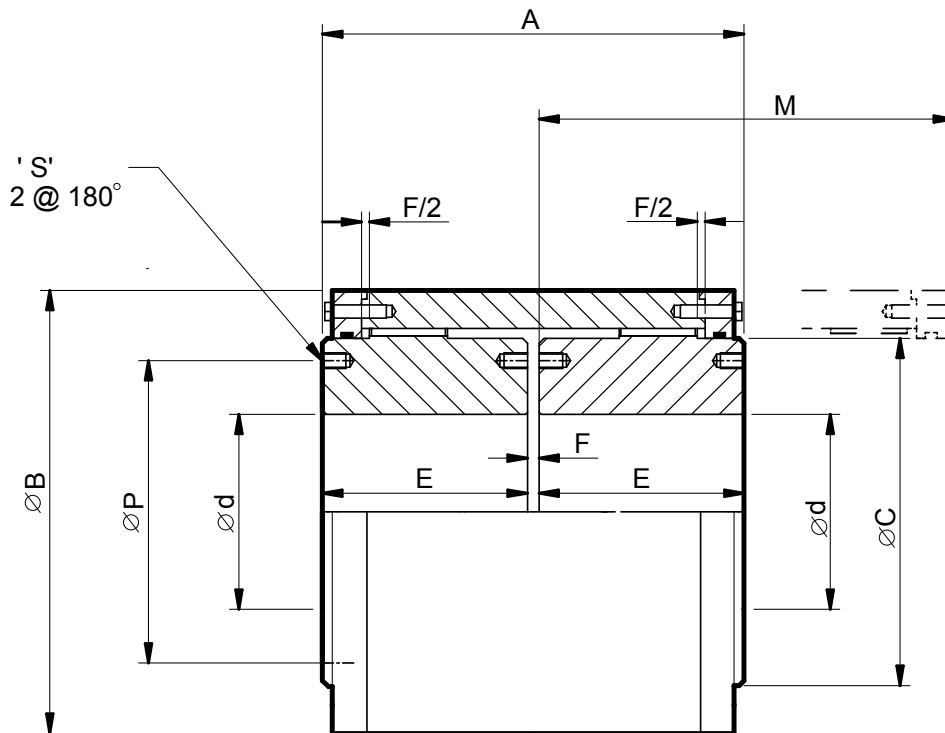
## ELIGN GEAR COUPLINGS

### Type ES Continuous Sleeve





	Tk	Tk <sub>max</sub>	P / N	A	ØB	ØC	Ød	E	F	M	ØP	S	 < °	 +/- mm	 kg	J	N <sub>max</sub>
	daNm	daNm	kW/rpm	mm	mm	mm	mm	mm	mm	mm	mm	mm	< °	+/- mm	kg	kgm <sup>2</sup>	rpm
<b>ES1600</b>	1600	3200	1.68	185	186	151	40 - 110 (35)	90	5	218	130	M8 x 12	2 X 0.75°	0.70	34	0.158	4700
<b>ES2200</b>	2200	4400	2.30	216	216	178	55 - 130 (50)	105	6	257	155	M8 x 12	2 X 0.75°	0.90	52	0.332	4350
<b>ES3200</b>	3200	6400	3.35	246	254	213	65 - 155 (60)	120	6	289	185	M10 x 15	2 X 0.75°	1.00	82	0.738	4000
<b>ES4500</b>	4500	9000	4.71	278	282	235	80 - 175 (75)	135	8	325	205	M12 x 18	2 X 0.75°	1.10	112	1.255	3800
<b>ES6200</b>	6200	12400	6.49	308	317	263	90 - 195 (85)	150	8	358	226	M16 x 24	2 X 0.75°	1.20	154	2.197	3600
<b>ES8400</b>	8400	16800	8.80	358	346	286	100 - 215 (95)	175	8	419	250	M16 x 24	2 X 0.75°	1.40	209	3.510	3450
<b>ES11500</b>	11500	23000	12.04	388	376	316	120 - 240 (115)	190	8	459	276	M16 x 24	2 X 0.75°	1.50	264	5.352	3300
<b>ES17400</b>	17400	34800	18.22	450	436	372	150 - 275 (145)	220	10	513	330	M20 x 30	2 X 0.75°	1.70	398	11.00	3050

# COUPLINGS

## ELIGN GEAR COUPLINGS

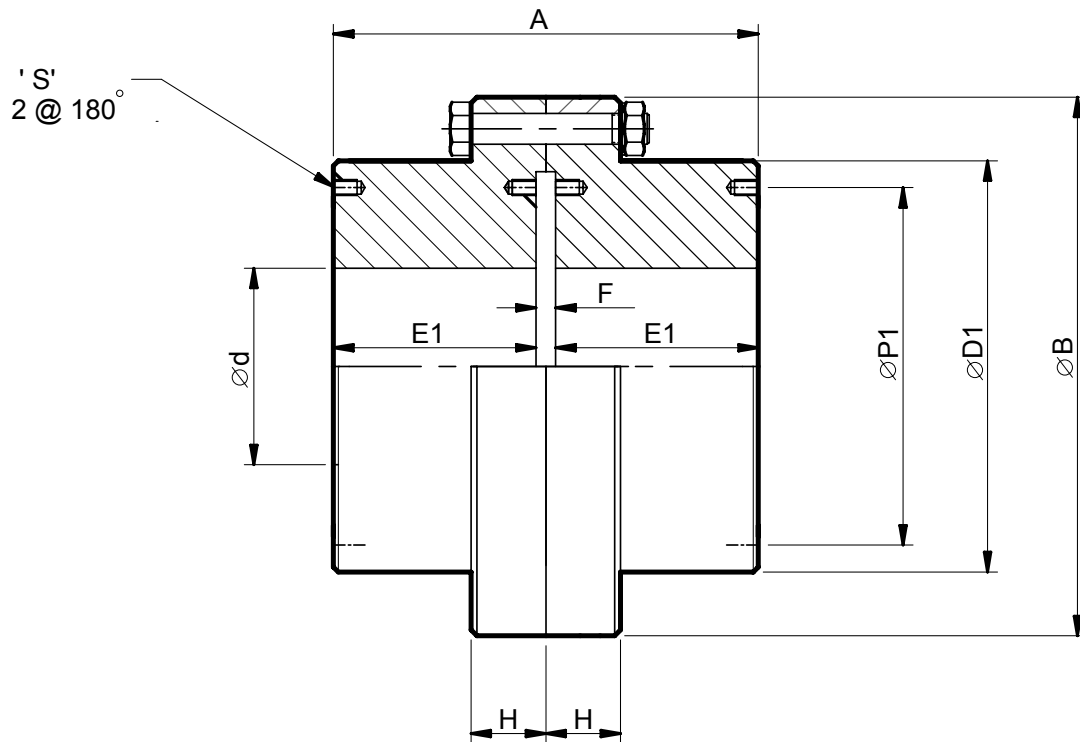
### Type ERR Fully Rigid



	Tk	Tk max	P / N	A	ØB	Ød1	ØD1	E1	F	H	M	ØP	ØP1	S	 kg	J	N max
	daNm	daNm	kW/rpm	mm	mm	mm	mm	mm	mm	mm	mm	mm	mm	mm	kg	kgm <sup>2</sup>	rpm
ERR130	130	260	0.14	87	111	15 - 55 (10)	80	40	7	14	74	-	-	-	4	0.005	7000
ERR280	280	560	0.29	101	141	20 - 75 (15)	104	47	7	19	84	-	-	-	8	0.015	6200
ERR500	500	1000	0.52	123	171	30 - 95 (25)	126	58	7	19	105	-	-	-	14	0.039	5650
ERR1000	1000	2000	1.05	155	210	35 - 110 (30)	152	74	7	22	123	-	-	-	26	0.102	5100
ERR1600	1600	3200	1.68	181	234	40 - 130 (35)	178	87	7	22	148	130	155	M8 x 12	38	0.196	4700
ERR2200	2200	4400	2.30	209	274	55 - 155 (50)	208	101	7	28.5	172	155	180	M8 x 12	61	0.450	4350
ERR3200	3200	6400	3.35	233	312	65 - 180 (60)	245	113	7	28.5	193	185	210	M10 x 15	91	0.871	4000
ERR4500	4500	9000	4.71	266	337	80 - 200 (75)	270	129	8	28.5	215	205	235	M12 x 18	120	1.37	3800
ERR6200	6200	12400	6.49	308	380	90 - 230 (85)	305	150	8	38	241	226	265	M16 x 24	175	2.59	3600
ERR8400	8400	16800	8.80	358	405	100 - 250 (95)	330	175	8	38	279	250	290	M16 x 24	232	3.91	3450
ERR11500	11500	23000	12.04	392	444	120 - 280 (155)	362	190	12	26	304	276	320	M16 x 24	287	5.66	3300
ERR17400	17400	34800	18.22	456	506	150 - 330 (145)	416	220	16	28.5	339	330	370	M20 x 30	430	11.50	3050

# COUPLINGS

---

NOTES

---

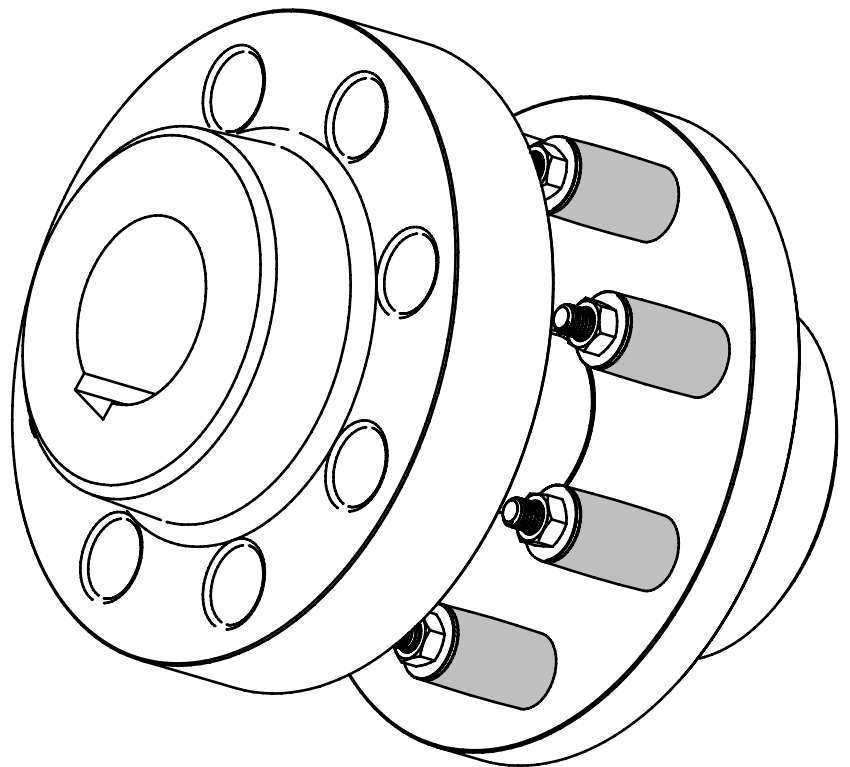

# ELFLEX

## FLEXIBLE PIN AND BUSH COUPLING

# COUPLINGS

## ELFLEX FLEXIBLE COUPLINGS

### Elfex Couplings

ELFLEX Flexible couplings transmit torque from one shaft to another and are particularly useful in cases where a limited amount of misalignment of the shafts is unavoidable.

ELFLEX flexible couplings are cushioned drive pin and bush type couplings that transmits the torque through rubber bushes which have an excellent capacity to absorb shock loads. The flanges are manufactured from high quality cast iron and are suitable for speeds up to the maximum limits as listed in the dimension tables.

### Features of Elfex Flexible Couplings

Permits drive in either direction and are suitable for driving all classes of machinery.

Low maintenance, Lubrication is not required.

No further adjustment is necessary after initial alignment.

Barrel shaped bushes ensure effective shock and vibration absorption.

The rubber bushes are tolerant to water,dust and other atmospheric conditions.

Facility to dismantle the machines simply by just removing the coupling bolts and rubber bushes.

The couplings work within the permissible limits of misalignment as per BS : 3170

Hubs are bored to suit the customers shaft size (see dimension tables for the minimum / maximum allowable bore) standard metric keyways conform to DIN-6885, PART-1 (unless otherwise specified)

Couplings can also be supplied bored to suit customers exact specifications or with the minimum / pilot bore conditions to permit machining by the customer. (the minimum / pilot bore is shown in brackets on the dimension pages)

ELFLEX couplings are also available with an integral brake drum (Type FBC)

### Coupling Misalignment

Maximum life and minimum maintenance for the coupling and connected machinery will result if the couplings are accurately aligned. ELFLEX couplings should be aligned within limits as shown in table below:

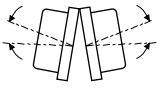
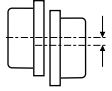
		
	< ° (max)	mm
EFC01-07	1.0°	0.15
EFC08-12	1.0°	0.2
> EFC14	1.0°	0.25
FC630- FC1600	1.0°	0.25



# COUPLINGS

## ELFLEX FLEXIBLE COUPLINGS

### Elflex Couplings Type EFC

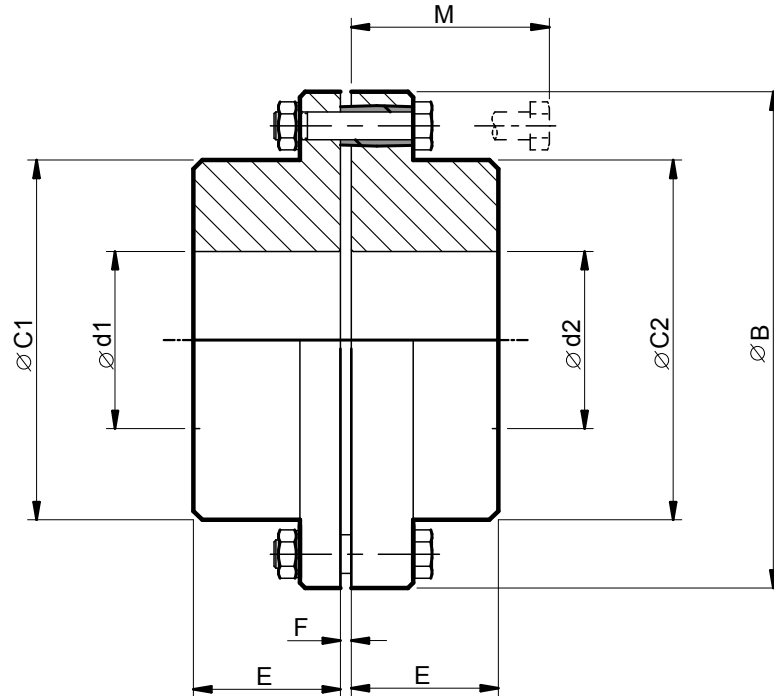



	Tk daNm	P / N kW/rpm	Ød1 mm	Ød2 mm	ØB mm	ØC1 mm	ØC2 mm	E mm	F mm	M mm	#	 Kg kg	J kgm <sup>2</sup>	N max rpm
EFC01	7	0.007	16 - 32	16 - 28 (12)	85	48	42	32	3	50	4	1.5	0.004	7860
EFC02	10.8	0.010	16 - 38	16 - 32 (12)	105	60	48	38	3	52	4	2.5	0.01	6360
EFC03	21	0.022	16 - 42	16 - 40 (12)	112	63	60	42	3	52	5	3	0.014	5960
EFC04	33	0.034	20 - 48	20 - 45 (16)	127	72	63	48	3	64	6	4.75	0.028	5260
EFC05	53	0.056	20 - 55	20 - 50 (16)	144	82	75	55	3	64	8	7	0.048	4635
EFC06	63.5	0.066	20 - 60	20 - 55 (16)	162	90	82	60	3	74	6	9.5	0.087	4120
EFC07	87	0.091	20 - 70	20 - 65 (16)	180	105	98	70	3	74	8	12	0.143	3710
EFC08	164	0.171	20 - 85	20 - 75 (16)	220	127	112	85	5	100	6	24	0.413	3035
EFC09	205	0.214	20 - 95	20 - 85 (16)	240	140	128	95	5	100	8	31	0.612	2780
EFC10	306	0.321	45 - 105	45 - 100 (40)	270	157	150	105	5	100	10	40	1.03	2475
EFC11	365	0.383	45 - 110	45 - 105 (40)	285	162	155	110	5	126	8	50	1.54	2345
EFC12	455	0.476	45 - 120	45 - 115 (40)	320	182	170	125	5	126	10	70	2.51	2085
EFC13	609	0.638	45 - 130	45 - 125 (40)	340	196	185	140	6	152	8	92	3.9	1965
EFC14	891	0.933	45 - 140	45 - 135 (40)	360	205	200	150	6	152	10	110	5	1855
EFC15	1204	1.26	60 - 160	60 - 160 (55)	410	235	235	170	6	152	12	153	8.9	1630
EFC16	1859	1.95	60 - 175	60 - 175 (55)	450	255	255	185	6	187	8	210	15.2	1480
EFC-17	2706	2.84	60 - 195	60 - 195 (55)	500	290	290	205	6	187	10	280	24.5	1335

# COUPLINGS

## ELFLEX FLEXIBLE COUPLINGS

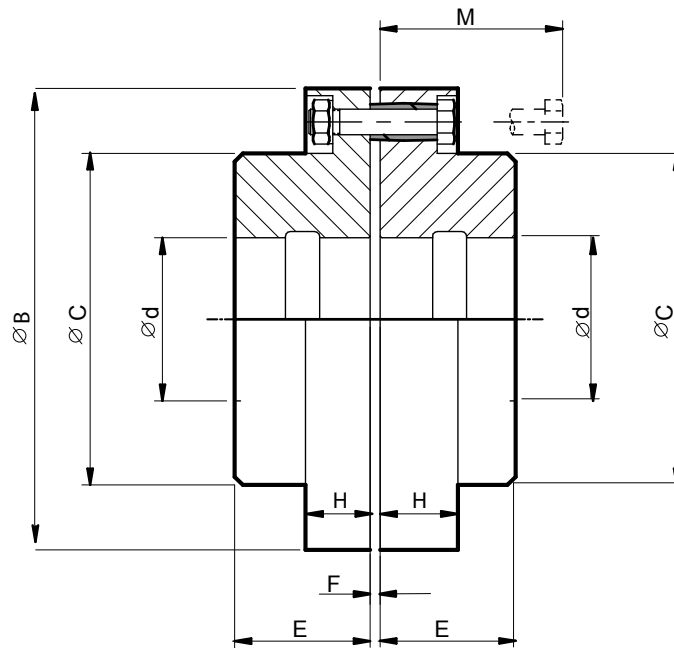
### Elflex Couplings Type FC





	Tk	P / N	$\varnothing d$	$\varnothing B$	$\varnothing C$	E	F	M	H	#	 kg	J	N max
	daNm	kW/rpm	mm	mm	mm	mm	mm	mm	mm		kg	kgm <sup>2</sup>	rpm
<b>FC630</b>	3200	3.35	120 - 230	630	360	260	12	110	120	14	410	66	1050
<b>FC710</b>	4500	4.7	120 - 240	710	390	280	12	130	135	18	560	114	940
<b>FC800</b>	6100	6.35	120 - 260	800	430	300	12	130	135	18	750	187	850
<b>FC900</b>	8600	8.95	140 - 290	900	480	320	12	150	152	12	990	308	750
<b>FC1000</b>	12200	12.68	180 - 320	1000	540	350	14	150	152	16	1300	474	670
<b>FC1120</b>	16500	17.16	230 - 350	1120	590	380	14	170	170	16	1700	824	600
<b>FC1250</b>	23000	23.88	240 - 380	1250	640	420	14	170	170	20	2150	1272	530
<b>FC1400</b>	32000	33.58	360 - 420	1400	720	460	14	190	195	14	3050	2213	480
<b>FC1600</b>	43000	44.77	280 - 460	1600	750	500	14	190	195	20	3950	4163	430

# COUPLINGS

## ELFLEX FLEXIBLE COUPLINGS

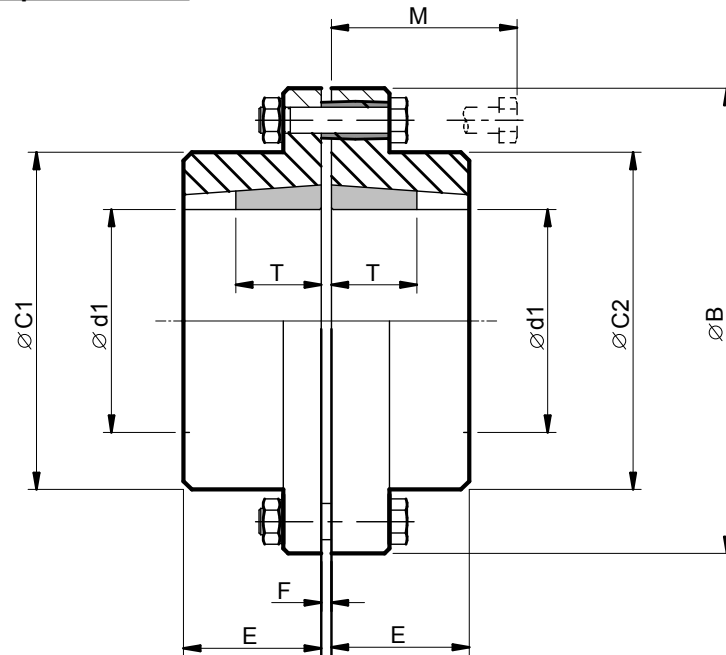
### Elfex Couplings with Taperlock Bush



	Tk daNm	P / N kW/rpm	Ød1 mm	ØB mm	ØC1 mm	ØC2 mm	E mm	F mm	M mm	#	T mm		 kg	J kgm <sup>2</sup>	N <sub>max</sub> rpm
EFC03	21	0.022	9 - 25	112	63	60	42	3	52	5	22.3	1108	3	0.014	5960
EFC04	33	0.034	11 - 32	127	72	63	48	3	64	6	25.4	1210	4.75	0.028	5260
EFC05	53	0.056	14 - 40	144	82	75	55	3	64	8	38.1	1615	7	0.048	4635
EFC06	63.5	0.066	14 - 40	162	90	82	60	3	74	6	38.1	1615	9.5	0.087	4120
EFC07	87	0.091	14 - 50	180	105	98	70	3	74	8	31.8	2012	12	0.143	3710
EFC08	164	0.171	16 - 60	220	127	112	85	5	100	6	44.5	2517	24	0.413	3035
EFC09	205	0.214	16 - 60	240	140	128	95	5	100	8	44.5	2517	31	0.612	2780
EFC10	306	0.321	35 - 75	270	157	150	105	5	100	10	76.2	3030	40	1.03	2475
EFC11	365	0.383	35 - 75	285	162	155	110	5	126	8	76.2	3030	50	1.54	2345
EFC12	455	0.476	35 - 90	320	182	170	125	5	126	10	89	3535	70	2.51	2085
EFC13	609	0.638	40 - 100	340	196	185	140	6	152	8	102	4030	92	3.9	1965

		d1																																						
		9	10	11	12	14	15	16	18	19	20	22	24	25	28	30	32	35	38	40	42	45	48	50	55	60	65	70	75	80	85	90	95	100						
EFC03	1108	●	●	●	●	●	●	●	●	●	●	●	●	●	*																									
EFC04	1210			●	●	●	●	●	●	●	●	●	●	●	●	●	●																							
EFC05	1615					●	●	●	●	●	●	●	●	●	●	●	●	●	●	●	*																			
EFC06						●	●	●	●	●	●	●	●	●	●	●	●	●	●	●	●	●	●	●	●	●	●	●	●	●	●	●	●	●	●	●	●			
EFC07	2012				●	●	●	●	●	●	●	●	●	●	●	●	●	●	●	●	●	●	●	●	●	●	●	●	●	●	●	●	●	●	●	●	●			
EFC08	2517					●	●	●	●	●	●	●	●	●	●	●	●	●	●	●	●	●	●	●	●	●	●	●	●	●	●	●	●	●	●	●	●	●		
EFC09						●	●	●	●	●	●	●	●	●	●	●	●	●	●	●	●	●	●	●	●	●	●	●	●	●	●	●	●	●	●	●	●	●	●	
EFC10	3030																		●	●	●	●	●	●	●	●	●	●	●	●	●	●	●	●	●	●	●	●		
EFC11																				●	●	●	●	●	●	●	●	●	●	●	●	●	●	●	●	●	●	●	●	●
EFC12	3535																		●	●	●	●	●	●	●	●	●	●	●	●	●	●	●	●	●	●	●	●	●	
EFC13	4040																			●	●	●	●	●	●	●	●	●	●	●	●	●	●	●	●	●	●	●	●	●

Keys marked \* require low profile key in accordance with DIN 6885/3.

# COUPLINGS

## ELFLEX FLEXIBLE COUPLINGS

### Elfex Coupling with Brake Drum Type FBC

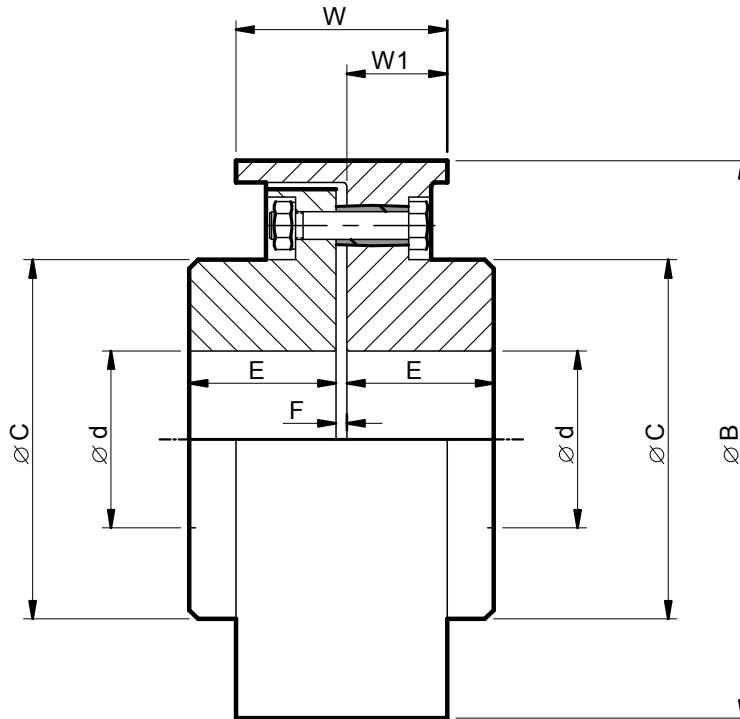

	Tk	P / N	Ød	ØB	ØC	E	F	W	W1		J	N max
	daNm	kW/rpm	mm	mm	mm	mm	mm	mm	mm	kg	kgm <sup>2</sup>	rpm
<b>FBC100</b>	12	0.013	16 - 25	100	40	32	3	75	40	3	0.015	5730
<b>FBC150</b>	20	0.021	16 - 32	150	54	42	3	85	43	8	0.09	3830
<b>FBC160</b>	22	0.023	16 - 32	160	54	42	3	85	43	9	0.13	3600
<b>FBC200</b>	64	0.067	16 - 55	200	92	60	3	95	46	17	0.32	2870
<b>FBC250</b>	90	0.094	16 - 60	250	105	75	3	120	60	25	1	2300
<b>FBC300</b>	250	0.262	16 - 85	300	140	95	3	160	75	58	2.5	1910
<b>FBC315</b>	300	0.314	16 - 85	315	140	95	3	160	75	62	2.85	1820
<b>FBC400</b>	356	0.373	45 - 115	400	190.5	120.7	3	180	100	128	9.94	1440
<b>FBC450</b>	450	0.471	45 - 115	450	190.5	120.7	3	200	100	165	15.4	1270
<b>FBC500</b>	983	1.029	45 - 135	500	235	146	3	225	112.5	244	27.5	1150

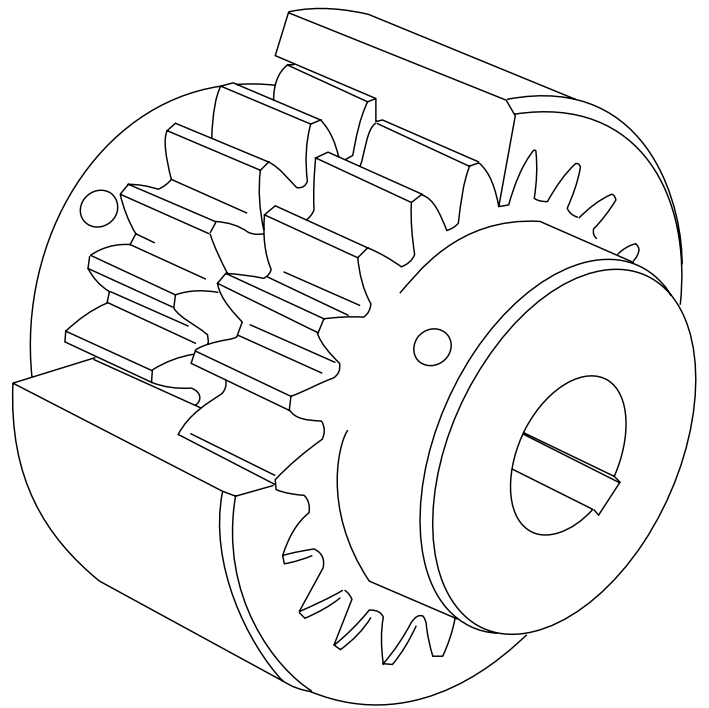

# NYLICON

**GEAR COUPLINGS WITH NYLON SLEEVE**

# COUPLINGS

## NYLICON COUPLINGS

### Gear Couplings with Nylon Sleeve

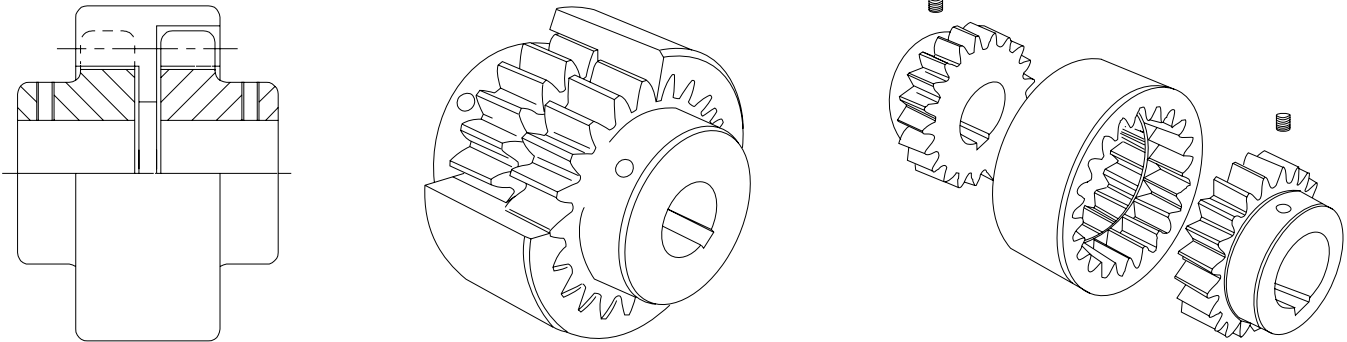

#### General Description

Nylicon flexible gear couplings, types X600, are available in three sizes and are ideal for small power drives with bore sizes up to 55mm (2.25 inches) diameter and a basic rated torque up to 463 Nm.

#### Uniform Loading

Thermosetting plastic sleeves provide non conductive assemblies. Staggered internal teeth ensure uniform loading and an internal central buffer ring between the two hubs promote axial location giving protection to the gear teeth.

#### Low Cost Option

They compensate for all types of shaft misalignment and allow a small amount of end float. Nylicon couplings are easy to assemble and require no maintenance giving low cost reliable service under the most arduous conditions of weather, atmospheric pollution or humidity.

#### Specification



Nylicon couplings are available pilot bored (i.e. without keyways) allowing the customer to finish machine bores and keyways to special requirements, or supplied with standard bores and keyways. Each size of coupling can have any combination of pilot and/or standard bores. Socket set screws and setting gauge are provided with each coupling.

# COUPLINGS

## NYLICON COUPLINGS

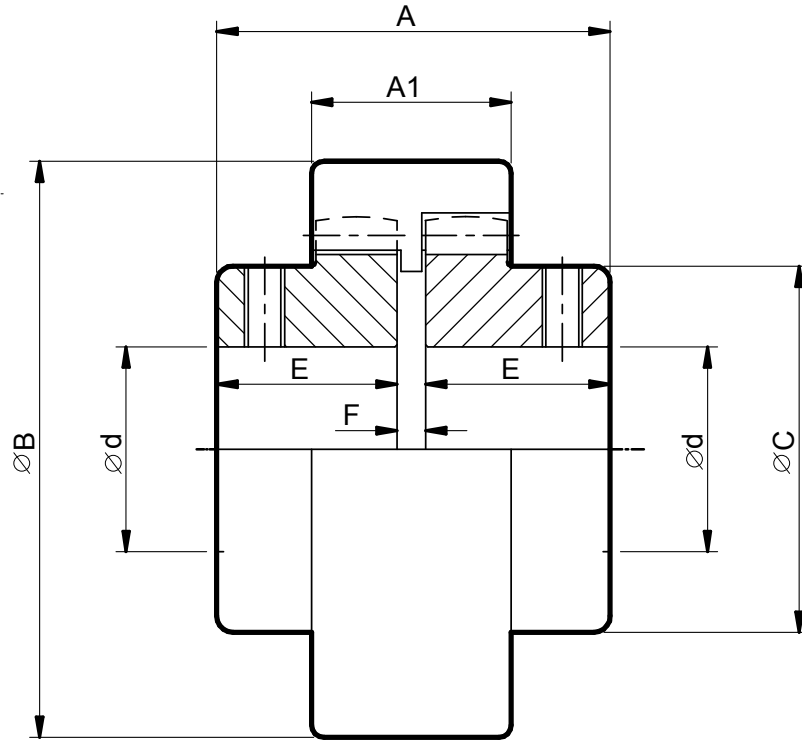
### Nylicon Gear Couplings with Nylicon Sleeve



	Tk daNm	P / N kW/rpm	A mm	A1 mm	ØB mm	ØC mm	Ød mm	E mm	F mm	 < °	 +/- mm	 kg	J kgm <sup>2</sup>	N max rpm
<b>01</b>	5.65	0.006	50	28	64	39	12 - 25 (10)	22	6	0.75	0.20	0.5	0.001	4000
<b>02</b>	22.0	0.023	76	42	89	58	18 - 38 (15)	35	6	0.75	0.20	1.68	0.048	3410
<b>03</b>	46.3	0.048	104	56	115	78	30 - 55 (28)	48	8	0.75	0.35	4.35	0.017	2630

# CONTACT US

## AUSTRALIA

### **Radicon Transmission (Australia) PTY Ltd**

Australia  
Tel: +61 488 054 028

## DENMARK

### **Benzler Transmission A/S** Fuglebævej 3D DK-2770 Kastrup, Denmark

Tel: +45 36 34 03 00  
Fax: +45 36 77 02 42

## EUROPE

### **Benzler TBA BV** Jachthavenweg 2 NL-5928 NT Venlo

Germany  
Tel: 0800 350 40 00  
Fax: 0800 350 40 01

Italy  
Tel: +39 02 824 3511

Netherlands & the rest of Europe  
Tel: +31 77 324 59 00  
Fax: +31 77 324 59 01

## FINLAND

### **Oy Benzler AB** Vanha Talvitie 3C FI-00580 Helsinki, Finland

Tel: +358 9 340 1716  
Fax: +358 10 296 2072

## INDIA

### **Elecon. Engineering Company Ltd.**

Anand Sojitra Road  
Vallabh Vidyanagar  
388120 Gujarat  
India

Tel: +91 2692 236513  
Fax: +91 2692 227484

## SWEDEN & NORWAY

### **AB Benzlers** AB Benzlers Box 922 (Porfyrgatan 7) 254 68 Helsingborg

Tel: +46 42 18 68 00  
Fax: +46 42 21 88 03

## THAILAND

### **Radicon Transmission (Thailand) Ltd** 700/43 Moo 6 Amata Nakorn Industrial Estate Tumbol Klongtumru Muang, Chonburi 20000 Thailand

Tel: +66 3845 9044  
Fax: +66 3821 3655

## UNITED KINGDOM

### **Radicon Transmission UK Ltd**

Unit J3  
Lowfields Business Park,  
Lowfields Way, Elland  
West Yorkshire, HX5 9DA

Tel: +44 1484 465 800  
Fax: +44 1484 465 801

## USA

### **Radicon USA Transmission Ltd**

1599 Lunt Avenue  
Elk Grove Village  
Chicago  
Illinois  
60007  
USA

Tel: +1 847 593 9910  
Fax: +1 847 593 9950

[www.benzlers.com](http://www.benzlers.com)

[www.radicon.com](http://www.radicon.com)



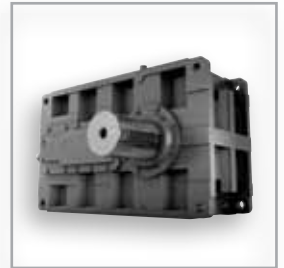
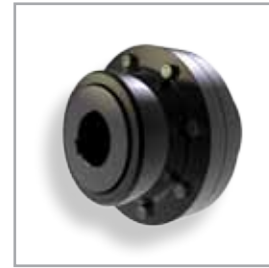
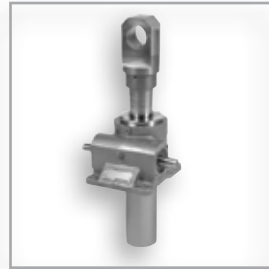

**benzlers** 

**radicon** 

**Benzlers**

Denmark +45 36 34 03 00  
 Germany +49 800-350 4000  
 Finland +358 9 340 1716  
 Italy +39 02 824 3511  
 Sweden +46 42 186 800  
           +46 19 178 090  
 The Netherlands +31 77 324 59 00  
[www.benzlers.com](http://www.benzlers.com)

**Radicon**

Thailand +66 3845 9044  
 United Kingdom +44 (0) 1484 465 800  
 USA +1 847 593 9910  
[www.radicon.com](http://www.radicon.com)